



RJ45 MODULAR PLUG CRIMP TOOL

DESCRIPTION

This tool was engineered specifically for barpa's RJ45 Modular Plugs, allowing you to crimp and cut all 8 conductors simultaneously with precision. Achieve up to 85% faster terminations, drastically reducing installation time. Equipped with 3 durable, long-lasting blades, this tool ensures consistent efficiency and extends its lifespan, making it a reliable choice for professionals.



SPECIFICATIONS

Material	Body: S45C Steel Crimping Part: AISI 4140 Alloy Steel
Color	Black and Blue
Compatibility	Shielded and Unshielded Modular Plugs
Weight (kg)	0,501
Dimensions (mm)	211 x 57 x 19,8

MAIN BENEFITS

Cuts perfect and precise
Includes 3 blades (1 pre-installed, 2 spares)
Reduces installation time

LOGISTIC INFORMATION

Code	Quantity (un)	Inner Box		Quantity (un)	Outer Box	
		Weight (kg)	Dimensions (mm)		Weight (kg)	Dimensions (mm)
82240600900	1	0,537	226x76x20	20	10,97	250x185x255

TECHNICAL DRAWING (mm)

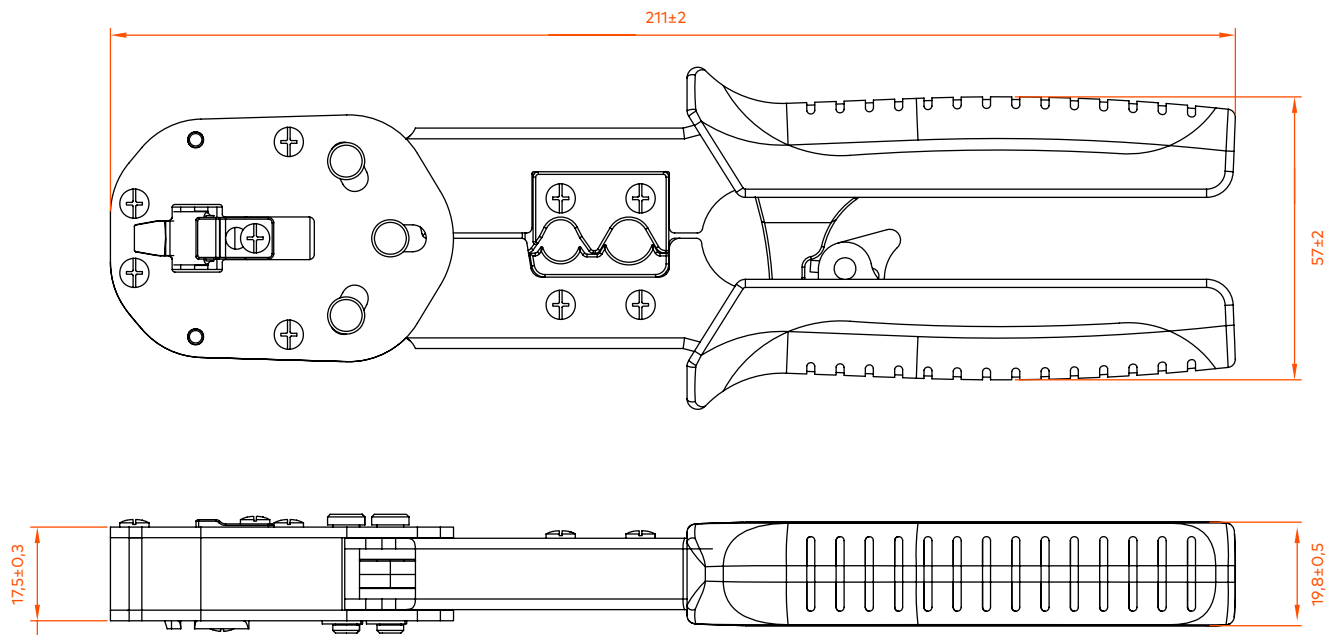

PACKAGING

This images are merely illustratives. We want you to see the importance we attach to the packaging.
We always work with products and materials that are easy to use.

