



## CABLE MANAGEMENT WITH OPEN BRUSH 1U

### DESCRIPTION

The 19" open brush panel is an effective solution for better cable organization and management within the cabinet. Its open design allows more practical cable routing, helping to maintain a cleaner and more efficient environment.



### APPLICABLE STANDARDS

- ANSI/EIA RS-310-D • IEC60297-2 • DIN41494 Part 1 and 7
- EIA 19-inch • Directive 2011/65/EU (RoHS)



### SPECIFICATIONS

Material	SPCC Cold Rolled Steel and brush
Color	Black (RAL 9005)
Dimensions (mm)	483x44

### LOGISTICS INFORMATION

Code	Unit Weight (kg)	Inner Box		Carton	
		Size (mm)	Quantity (un)	Size (mm)	Quantity (un)
82390207100	0,242	500x50x25	1	510x290x390	77

### TECHNICAL DRAWING (mm)

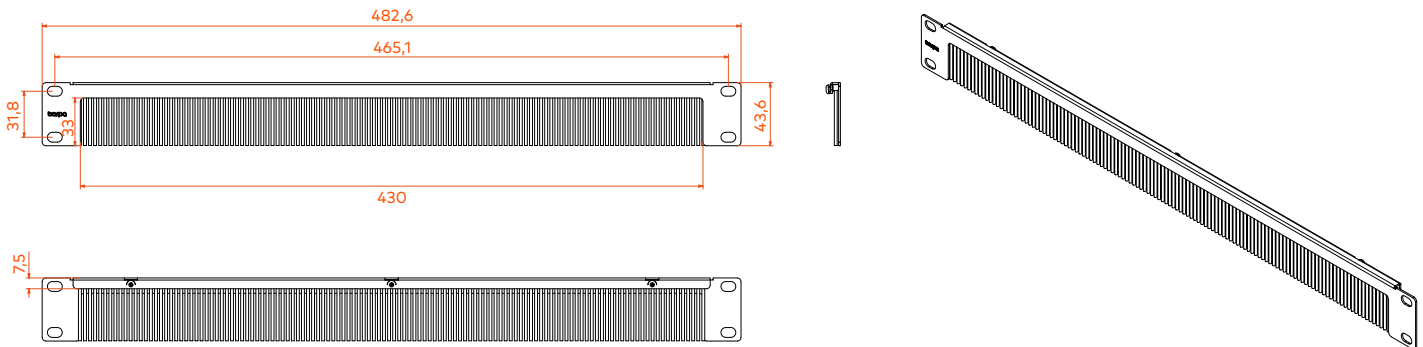

As part of our goal to achieve quality excellence, our barpa System Warranty can give you 25 years products and solution assurance of compliance with the industry performance standard comparing with the class installed. This warranty applies to network infrastructure installations that was made by an approved barpa partner using an barpa solution (end-to-end). For more informations go to our website.

This document is authored and owned by barpa . It is forbidden to reproduce in whole or in part without mentioning its authorship, as well as modification of its content or context. All specifications are subject to change without notice. The pictures/drawings are merely illustrative.

More information: [info@barpa.eu](mailto:info@barpa.eu) or in [www.barpa.eu](http://www.barpa.eu)

datasheet n° b171\_0 | date: 08/24

approved by: Ana Barbosa